

## 2刃深溝專用長頸球型立銑刀 BALL NOSE-LONG NECK-2 FLUTES

> 998V-D

WC=91 Co=9 HRA=93.2 抗折(Rupture)=4000N/mm<sup>2</sup> 粒徑(Grain Size)=0.2μm



### 形狀寸表法 Dimensions

單位 (Unit) : mm

型號 MODE	R角	刃長 l	有效長 L1	柄徑 D	全長 L
05022	0.25R	0.75	2	4	50
05042	0.25R	0.75	4	4	50
05062	0.25R	0.75	6	4	50
06022	0.3R	0.9	2	4	50
06042	0.3R	0.9	4	4	50
06062	0.3R	0.9	6	4	50
08042	0.4R	1.2	4	4	50
08062	0.4R	1.2	6	4	50
08082	0.4R	1.2	8	4	50
10062	0.5R	1.5	6	4	50
10082	0.5R	1.5	8	4	50
10102	0.5R	1.5	10	4	50
10122	0.5R	1.5	12	4	50
15062	0.75R	2.3	6	4	50
15082	0.75R	2.3	8	4	50
15102	0.75R	2.3	10	4	50
15122	0.75R	2.3	12	4	50
15142	0.75R	2.3	14	4	50
15162	0.75R	2.3	16	4	50
15182	0.75R	2.3	18	4	50
15202	0.75R	2.3	20	4	50
20082	1R	3	8	4	50
20102	1R	3	10	4	50
20122	1R	3	12	4	50
20142	1R	3	14	4	50
20162	1R	3	16	4	50
20182	1R	3	18	4	50
20202	1R	3	20	4	50
25082	1.25R	4	8	4	50
25122	1.25R	4	12	4	50
25162	1.25R	4	16	4	50
30102	1.5R	4.5	10	6	50
30122	1.5R	4.5	12	6	50
30162	1.5R	4.5	16	6	60
30202	1.5R	4.5	20	6	60
30252	1.5R	4.5	25	6	75

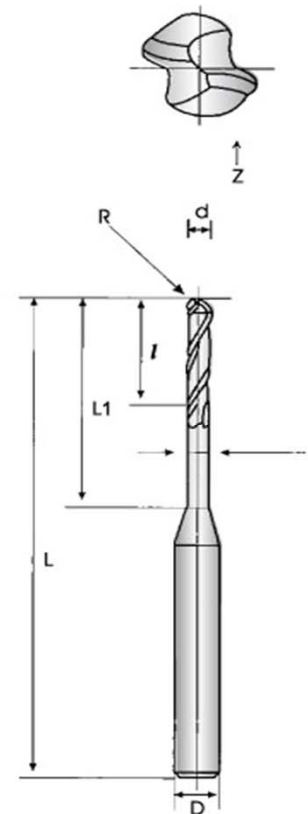

## 2刃深溝專用長頸球型立銑刀 BALL NOSE-LONG NECK-2 FLUTES

> 998V-D

WC=91 Co=9 HRA=93.2 抗折(Rupture)=4000N/mm<sup>2</sup> 粒徑(Grain Size)=0.2μm



### 形狀寸表法 Dimensions

單位(Unit) : mm

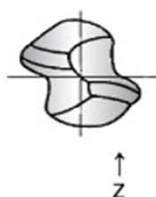

R

$\bar{I}_d$

Z

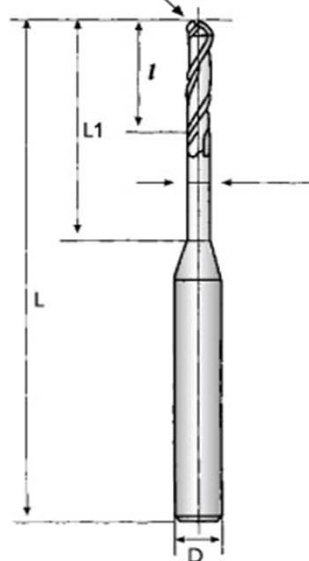

型號 MODE	R角	刃長 I	有效長 L1	柄徑 D	全長 L
40122	2R	6	12	6	50
40162	2R	6	16	6	60
40202	2R	6	20	6	75
40252	2R	6	25	6	75
40302	2R	6	30	6	75

99 Series